

# Va'eira – וארא

(“and He appeared”)

שָׁלִיט  
Sovereign

In this week's parasha we learn that God appeared to Moshe (Moses) and told him that He would redeem the people of Isra'el from their forced labor of the Egyptians and rescue them. God heard the groans of His people and remembered His covenant with them. The Lord tells Moshe (Moses) and Aharon (Aaron) to go before Pharaoh and to tell him to send God's people to the wilderness so that they may worship Him. Moshe and Aharon would obey God and go before Pharaoh, and God would show Pharaoh and the world many signs and wonders. This was to show Pharaoh and the world that the Lord is God alone. Despite all that Pharaoh witnessed, his heart ♥ was hardened to the things of God. We learn throughout this portion that when we walk in our will just as Pharaoh did, we will find ourselves in opposition to the will of God.

Then I will take you for My people, and I will be your God: and you shall know that I am the Lord your God who brought you out from under the burden of the Egyptians.

Exodus 6:7

## Focus Passage of Scripture

Exodus 6:2 – 9:35



Let's look at the scriptures together.

In today's Torah's portion we start out in Exodus chapter 6 seeing that God appeared to Moshe. In Exodus 6:2 -10, we see God telling Moshe that He will redeem His people and bring them out from under the bondage of Egypt so that they could praise Him. He would bring them to the land which was promised to Avraham (Abraham), Yitz'chak (Issac), and Ya'akov (Jacob). Moshe tells the people what the Lord had spoken but the people did not believe him. God then tells Moshe to go before Pharaoh and tell him to send His people forth, but Moshe

Moshe was 80 years old.  
Remember that eight is the number of newness.  
Aharon was 83.  
Three is indication of a revealing.

tells God that his own people would not believe him because he was a poor speaker. We see that the Lord provides Aharon (Aaron) Moshe's brother to be his prophet. Moshe would say what the Lord had commanded him, and Aharon would tell Pharaoh. Moshe and Aharon had a willingness to be used by God, so they trusted and obeyed

## Pray First

Father God,  
We praise You today for You are worthy of our praise. You have redeemed us and we desire to worship You. Please help us to trust You and to obey Your commands as we study the truth of Your word today.

In Yeshua's name we pray  
Amen

God. They received God's mercy because of their obedience. In Exodus 7:3-4 we see God saying that He will increase His signs and wonders in the land of Egypt, but Pharaoh will not listen to them. This is where we first see Pharaoh opposing the will of God, and as Pharaoh does this, his heart hardens. Then in Exodus 7:6-7 we see Moshe and Aharon being obedient to God. Moshe and Aharon obey the commands from the Lord and tell Pharaoh all that God commanded. Throughout chapters seven, eight and nine of Exodus, God tells Moshe and Aharon to tell Pharaoh "Send My people forth so that they may worship Me." Unfortunately, Pharaoh does not want to obey God's commands, and this further hardens Pharaoh's heart. ❤️

In Exodus 7:6-13 Moshe and Aharon did exactly as they were told.

God told Aharon to throw his staff in front of Pharaoh and his servants when Pharaoh says "Perform a miracle." Aharon obeyed and the staff turned into a snake. Pharaoh's magicians did the same with their staffs, but Aharon's staff swallowed up theirs. Because the magician's staffs also turned to snakes, Pharaoh's heart ❤️ hardened.

In Exodus 7:14-25 Moshe and Aharon are told go to Pharaoh at the riverbank and to tell Pharaoh, "Send My people forth so that they may worship Me in the desert, but until now you have not listened, so the Lord says this will let you know I am Lord." The Lord told Aharon to stretch out his staff over the rivers, canals, ponds, and reservoirs so that they turned to blood. Aharon obeyed. The rivers turned to blood and so did all the water in Egypt. The water stank so bad the Egyptians could not drink from the water. The Pharaoh's magicians also turned the rivers to blood, so Pharaoh's heart ❤️ was hardened.

In Exodus 8 and 9 we continue to see Pharaoh's unwillingness to respond to God. Exodus 9:13-16 God tells Moshe to get up early in the morning, stand before Pharaoh and say to him, "Here is what the Lord says, 'Send My people forth so that they can worship Me. For this time, I will inflict My plagues upon you, yourself, on your officials and on your people so that you will realize that I am without equal in all the earth. By now I could have stretched out My hand and struck you and your people with such severe plagues that you would have been wiped off the earth. But I have you alive to show you My power so that My name may resound throughout the whole earth.'" God caused a hailstorm to come and warned Pharaoh what would happen. Pharaoh's servants who feared God hid in their houses along with their livestock but those who did not fear God did not listen and all they had was destroyed. The lesson that we learn from the passage is that disobedience to God's commands hardens our heart. If we do obey His commands, we will have the mercy of God and we will want to continue to serve Him. We do not want to look to this world as Pharaoh did. He thought he owned the children of Isra'el, but they and all who obeyed Him belonged to God. Just as Pharaoh learned what would happen if he did not obey, we also must decide: Is my heart wanting what God wants? Do I seek the things of this world, or do I desire God's will for my life?



## A Closer Look

“For the Tanakh (Scripture) says to Pharaoh, it is for this very reason that I raised you up, so that in connection with you I might demonstrate My power, so that My name might be known throughout the world.” - Romans 9:17

In this week’s New Testament passage of Scripture, we see God is Sovereign. He knows all things and He created everything.

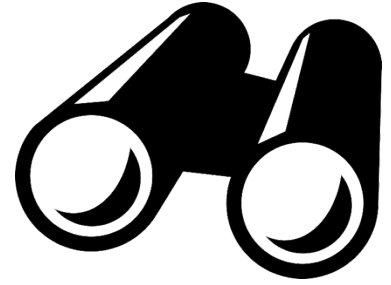

In Romans 9:16 – we learn that one’s standing with God does not depend on human desires or efforts, but on God Who has mercy. Romans 9:17 goes on to show God telling Pharaoh it is for this reason that God raised him up so that God could demonstrate His power and that His name might be known throughout the world. In our Torah

portion this week (Exodus 6:2 – 9:35), God demonstrated His power throughout Egypt so that Pharaoh and the world would know HE is God. God was in charge not Pharaoh. God knew that despite all the mighty acts, Pharaoh would harden his heart. God speaks to us also through His word and reveals His authority. When we submit to Him our heart will not be hardened as Pharaoh’s was.

Roman’s 9:14-24 shows us that the will of God will be fulfilled. God will accomplish His purposes. God was going to redeem His people from their bondage so they could worship Him. This did not depend on Pharaoh obeying God. Because Pharaoh wanted his own will, we see disaster come upon Egypt and all who lived in Egypt. All men are created equal in God’s eyes. He has the authority to use us whether we do the right thing or the wrong thing. However, we want our hearts to be submissive to God. When we refuse to submit to Him, we are in opposition to God. Regardless of the decision we make He will manifest His glory. We, like Pharaoh, have a choice to make: “Will I respond to the truth of God’s word, or will I harden my heart as Pharaoh did?”

### Ezekiel 28:25 -29:21

In this passage of Scripture, we see another example of God telling in advance what will happen to Egypt. God is going to redeem His people and keep His covenant with Isra’el. His will is going to be accomplished.

Yechezk’el (Ezekiel) is commanded by God to tell Pharaoh that although Pharaoh thought he owned the Nile, that is not the case. God owns the Nile. God created everything and He owns everything, not man. God controls everything, not Pharaoh. In Ezekiel 3, God calls Pharaoh a crocodile! This is due to Pharaoh’s hardened heart. Pharaoh had a false confidence in the world and in his power. We can do that in our own lives. We can look to the things of this world rather to God and His commands. He has given us the saving power of His word and we are to obey all that He commands us to do. These lessons continually teach us to submit to God and trust in His saving power.



Pray First  
Father God,  
We praise You because  
You are Omniscient. You  
demonstrate Your power  
so that we may see Your  
glory. Please help us  
keep our heart tender to  
the truth of the Gospel.

In Yeshua’s name we  
pray,  
Amen

Read Romans 9:14-24  
Ezekiel 28:25-29:21

Refer to Exodus 6:16-25 and complete the chart above with the names of Levi's descendants.

## The Sons of Levi

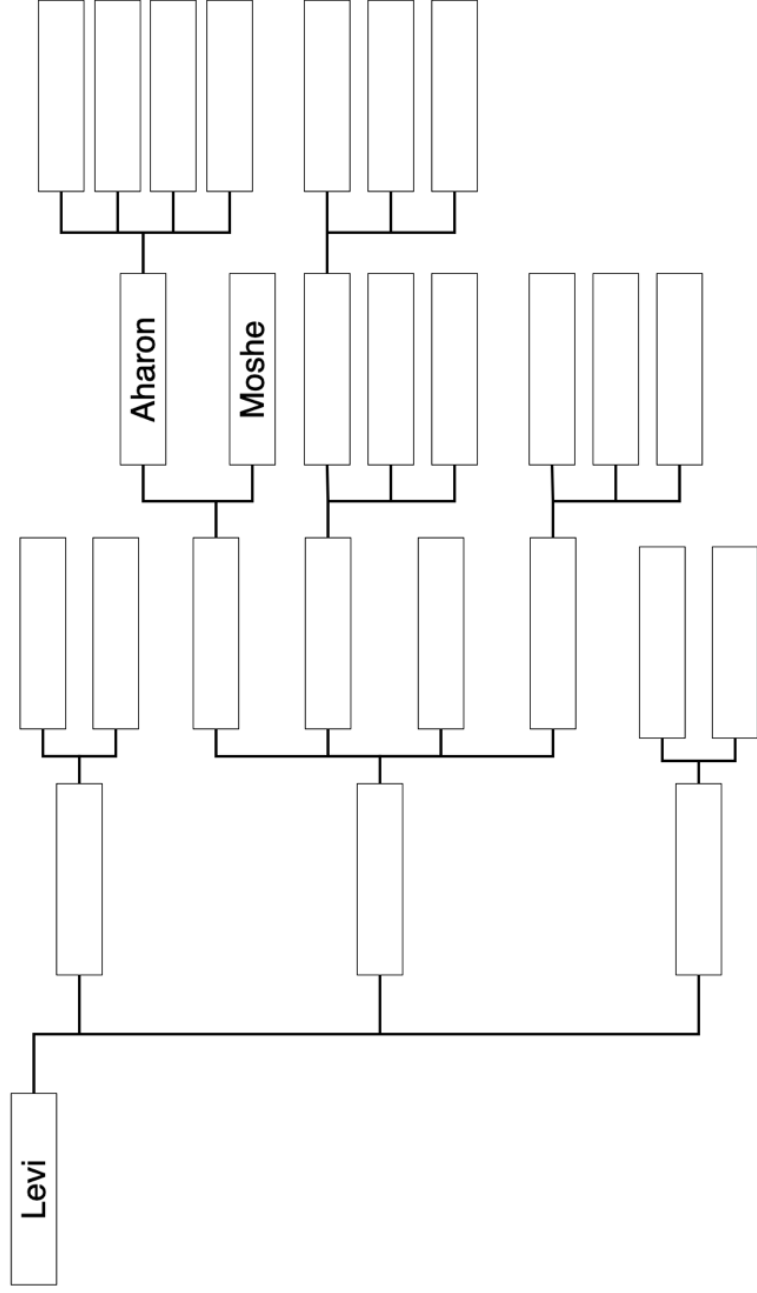

## Recap Review

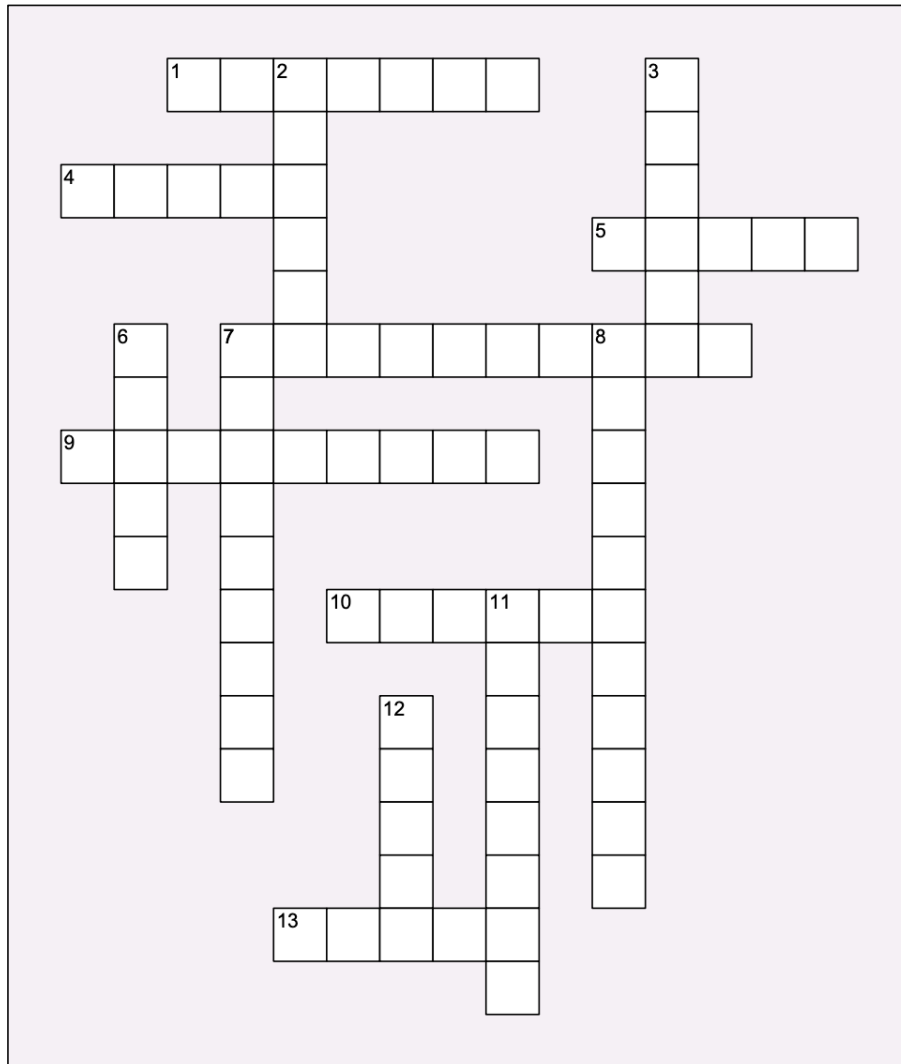

### Across

- 1: To give our deepest affection or highest praise
- 4: The first plague God placed on Egypt
- 5: The second plague God used to demonstrate His power to Pharaoh
- 7: Knowing everything
- 9: Fifth plague God placed in Egypt
- 10: Age of Moshe when he went before Pharaoh
- 13: Who the Lord first commanded to speak to Pharaoh

### Down

- 2: To rescue or deliver from the consequence of sin
- 3: Brother to Moshe
- 6: Fourth plague placed in Egypt
- 7: Willing to do what you are told to do; to follow a law or rule
- 8: Age of Aharon when he went before Pharaoh
- 11: Refusing to see the truth
- 12: Third plague placed on Egypt

